

BPW braked axles with flange-mounted brake drums

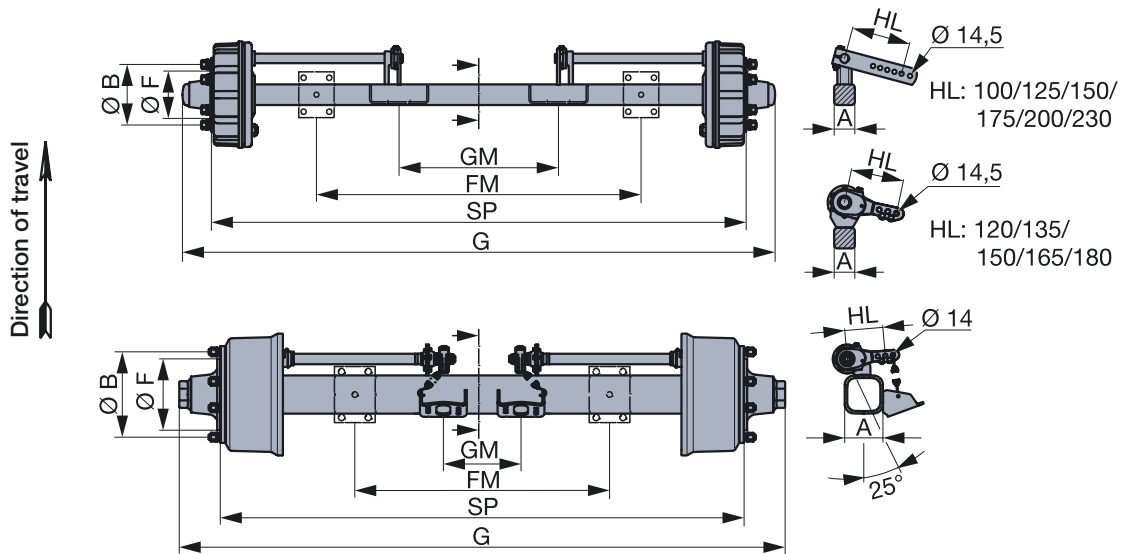

Axle type	Track SP mm	Spring centre FM mm	Overall length G mm	Air cylinder centres GM mm	Axle cross section A mm	Wheel bearing designation outer/inner	Number of wheel studs			Wheel connection			BPW order no.	
							$\varnothing F$ mm	$\varnothing B$ mm	Thread	Wheel brake type	up to 25 km/h	up to 40 km/h	Brake lever	Manual slack adjuster
												up to 60 km/h	up to 65 km/h maximum kg	
GS 5506	1700	1200	1904	560	70	32207-32013x	6	160	205	M18x1,5	N 3006-3	55.63.443.000	55.63.443.078	130
GS 5506	1700	1200	1908	535	70	32207-32013x	6	160	205	M18x1,5	N 3108-3	55.63.454.125	55.63.454.126	160
GS 5506	1700	1200	1908	485	70	32207-32013x	6	160	205	M18x1,5	N 4008-3	55.63.447.000	55.63.447.001	182
GS 5508	1700	1200	1908	535	70	32207-32013x	8	220	275	M20x1,5	N 3108-3	55.63.454.127	55.63.454.128	165
GS 5508	1700	1200	1908	485	70	32207-32013x	8	220	275	M20x1,5	N 4008-3	55.63.447.002	55.63.447.003	187
GS 7008	1700	1100	1960	515	80	30210-32014x	8	220	275	M20x1,5	N 3108-3	55.67.454.157	55.67.454.158	200
GS 7008	1700	1100	1960	470	80	30210-32014x	8	220	275	M20x1,5	N 4008-3	55.67.447.002	55.67.447.003	222
GS 8008-1	1700	1100	1943	525	90	32213-32215	8	220	275	M20x1,5	N 3108-3	55.70.454.109	55.70.454.110	224
GS 8008-1	1700	1100	1942	475	90	32213-32215	8	220	275	M20x1,5	N 4008-3	55.70.447.000	55.70.447.001	266
GS 11010-1	2050	1100	2357	553	120x15	32310-33116	10	280	335	M22x1,5	FL 4112	*55.88.460.002		350
GS 12010	2050	1100	2357	553	150x10	33213-33118	10	280	335	M22x1,5	FL 4118	*55.72.449.000		370

Standard offset ET 0 mm

Note: In EC member states, EC Directive 71/320, most recently amended by Directive 98/12/EC, requires automatic slack adjusters for trailers > 3.5 t gross weight. According to the motor vehicle construction and use regulations applicable in Germany, no automatic slack adjuster is required for speeds up to 60 km/h. Types without spring pads and air cylinder brackets. Other dimensions available on request.

Special equipment: • Spring pads • Air cylinder brackets for piston and diaphragm cylinders • Manual slack adjusters BPW type GSK and automatic slack adjusters BPW type ECO-Master for all brake sizes • ABS for axle type GS 7006 and for brake sizes 300 x 60 / 310 x 80 / 400 x 80 / 410 x 120 / 410 x 180



Equipped with flat cam and wing cam brakes, these axles provide optimal deceleration support and are individually designed for use at speeds of up to 65 km/h according to vehicle type and area of operation. Static axle loads of between 1,000 - 16,000 kg coupled with a special camshaft bearing make BPW braked axles an important factor towards even smoother, problem-free operation. The brake camshaft seat and all brake cylinder brackets are tailored to each individual vehicle.

BPW braked axle stubs with flange-mounted brake drums

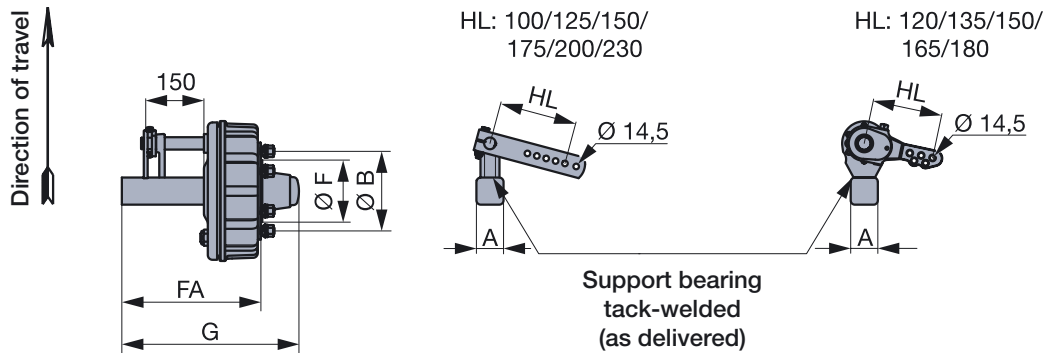

Axle stub type	Overall length G mm	Flange length FA mm	Axle cross section A mm	Wheel bearing designation outer/inner	Wheel connection				BPW order no.			
					Number of wheel studs	ø F mm	ø B mm	Thread	Wheel brake type	Brake lever	Manual slack adjuster	
									up to 25 km/h	up to 40 km/h	up to *60 km/h	up to 65 km/h maximum kg
GSST 5506	400	300	70	32207-32013x	6	160	205	M18x1,5	N 3006-3	58.63.443.000	58.63.443.001	44
GSST 5506	445	347	70	32207-32013x	6	160	205	M18x1,5	N 3108-3	58.63.454.104	58.63.454.105	61
GSST 5506	456	358	70	32207-32013x	6	160	205	M18x1,5	N 4008-3	58.63.447.000	58.63.447.001	72
GSST 5508	445	347	70	32207-32013x	8	220	275	M20x1,5	N 3108-3	58.63.454.106	58.63.454.107	63
GSST 5508	456	358	70	32207-32013x	8	220	275	M20x1,5	N 4008-3	58.63.447.002	58.63.447.003	75
GSST 7008	477	353	80	30210-32014x	8	220	275	M20x1,5	N 3108-3	58.67.454.113	58.67.454.114	75
GSST 7008	488	364	80	30210-32014x	8	220	275	M20x1,5	N 4008-3	58.67.447.002	58.67.447.003	86
GSST 8008-1	465	350	90	32213-32215	8	220	275	M20x1,5	N 3108-3	58.70.454.100	58.70.454.101	78
GSST 8008-1	480	365	90	32213-32215	8	220	275	M20x1,5	N 4008-3	58.70.447.000	58.70.447.001	89
GSST 11010-1	960	809	120x15	32310-33116	10	280	335	M22x1,5	FL 4112	*58.88.460.012		155

Standard offset ET 0 mm

Note: In EC member states, EC Directive 71/320, most recently amended by Directive 98/12/EC, requires automatic slack adjusters for trailers > 3.5 t gross weight. According to the motor vehicle construction and use regulations applicable in Germany, no automatic slack adjuster is required for speeds up to 60 km/h. Other dimensions available on request.

Special equipment: • Air cylinder brackets for piston and diaphragm cylinders • Manual slack adjusters BPW type GSK and for all brake sizes • Automatic slack adjusters BPW type ECO-Master for all brake sizes • ABS for axle type GS 7006 and for brake sizes 300 x 60 / 310 x 80 / 400 x 80 / 410 x 120 / 410 x 180