

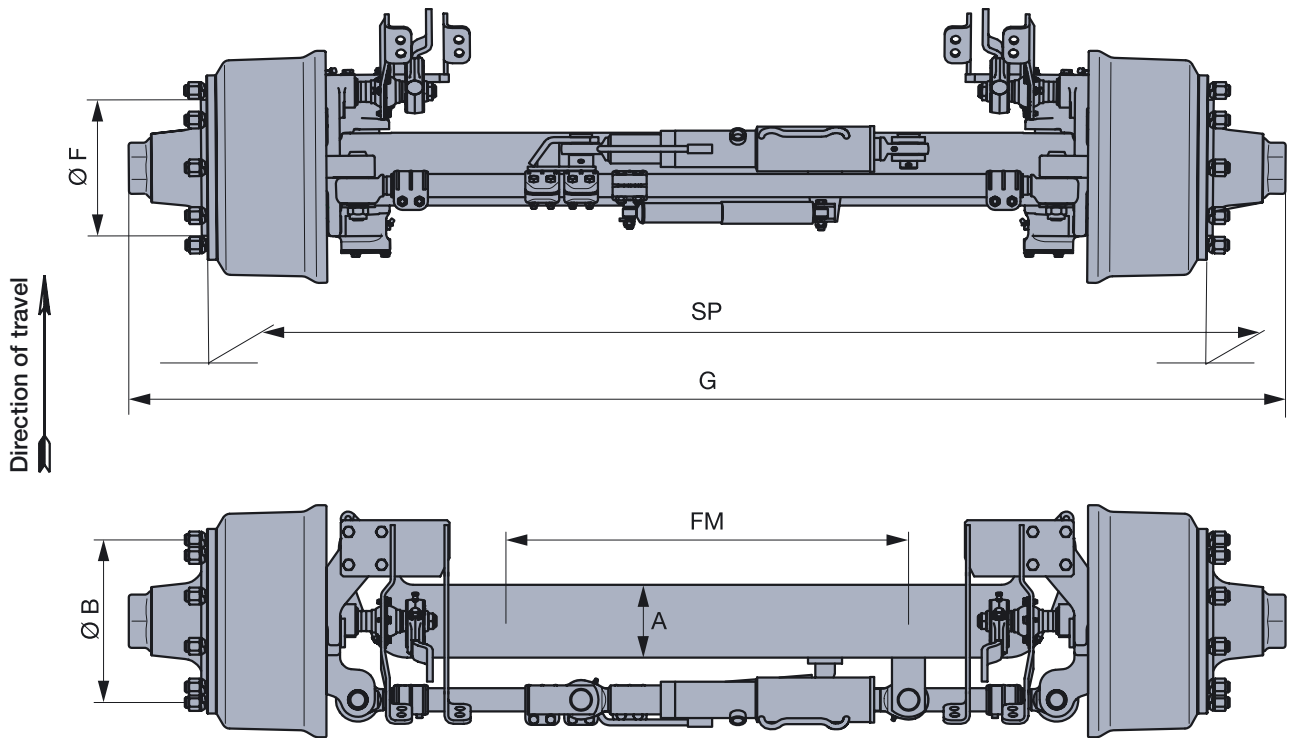

**BPW self-steering axle**



Axle type	Track SP mm	Spring centre FM mm	Overall length G mm	Axle cross section A mm	Wheel brake type	Number of wheel studs	Wheel connection			Static axle load kg				
							$\varnothing F$ mm	$\varnothing B$ mm	Thread	up to 25 km/h	up to 40 km/h	up to 60 km/h *up to 65 km/h maximum	BPW order no. with manual slack adjuster	kg
GSLA 7008	1950	700	2214	120x15	N 3108-3	8	220	275	M20x1,5	7500	7000	6500	36.67.454.153	275
GSLA 8008-1	1950	700	2197	120x15	N 3108-3	8	220	275	M20x1,5	9500	8500	8000	36.70.454.108	300
GSLA 8008-1	1950	700	2191	120x15	N 4008-3	8	220	275	M20x1,5	9500	8500	8000	36.70.447.114	320
GSLA 11010-1	1950	830	2263	120x15	FL 4112	10	280	335	M22x1,5	12.000	10.500	10.000	*36.88.460.040	395
GSLL 12010	2050	830	2383	150X16	FL 4118	10	280	335	M22x1,5	-	12.000	11.000	*36.72.449.000	540



Designed for speeds of up to 65 km/h, the self-steering axle makes for reduced stress on road surfaces, tyres and vehicles. It ensures secure straight-ahead travel and quick steering response when travelling through bends. Their solid and hollow axle beams easily handle axle loads of 7,000 - 16,000 kg. Special features include a patented thrust bearing, flat cam and wing cam brakes as well as welded brackets optimally tailored to the brake cylinders. There is one further feature, namely the optional power steered facility with hydraulic cylinders.

## BPW positive-steering axles

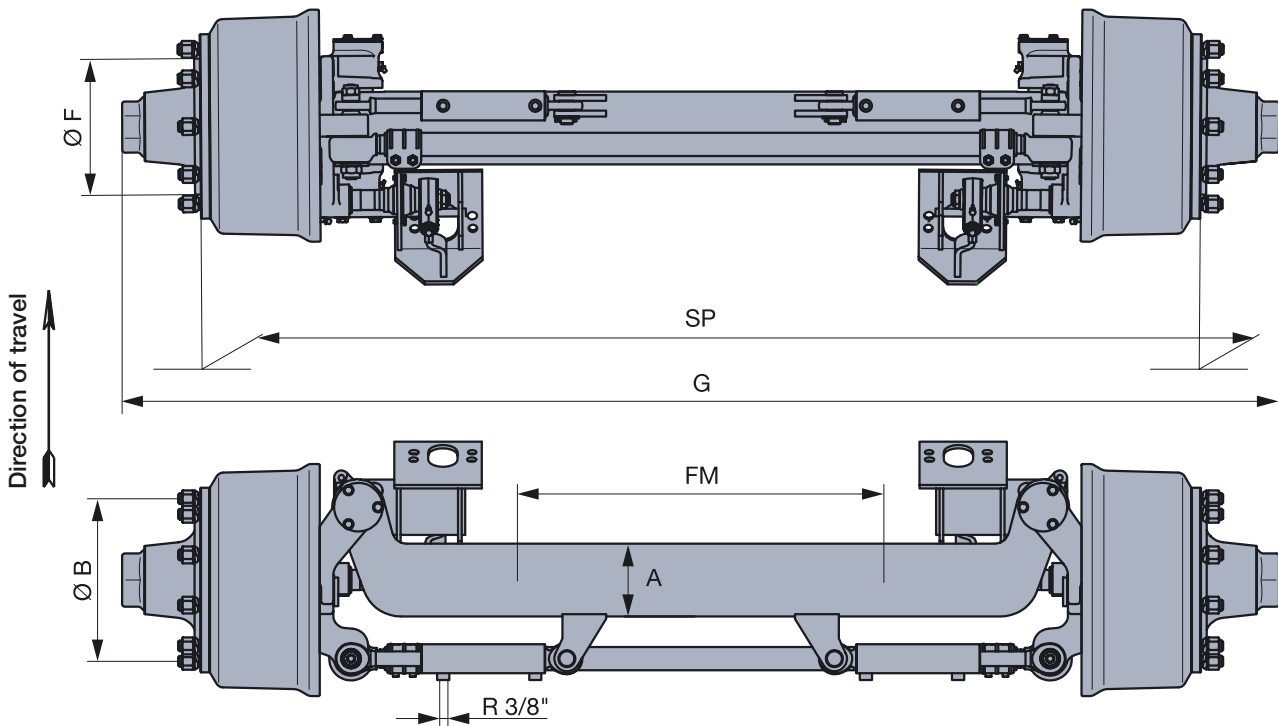

Wheel bearings acc. to tab. page 29. – Standard offset ET 0 mm

Note: In EC member states, EC Directive 71/320, most recently amended by Directive 98/12/EC, requires automatic slack adjusters for trailers > 3.5 t gross weight. According to the motor vehicle construction and use regulations applicable in Germany, no automatic slack adjuster is required for speeds up to 60 km/h. Types without spring pads and air cylinder brackets. Standard equipment: Air cylinder brackets for diaphragm cylinders and manual slack adjuster. Other dimensions available on request.

Special equipment: • Spring pads • Brake lever • ABS • Air cylinder brackets for piston cylinders • Automatic slack adjuster BPW type ECO-Master