

BPW hydro-pneumatic suspension GSOH

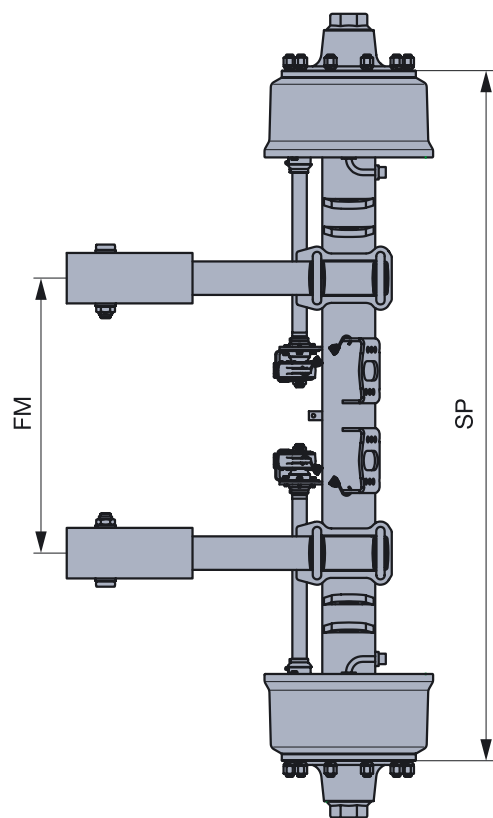

Direction of travel

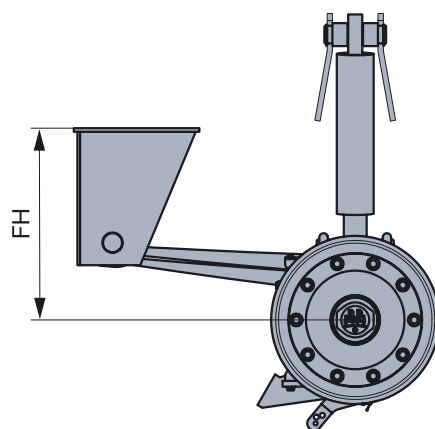

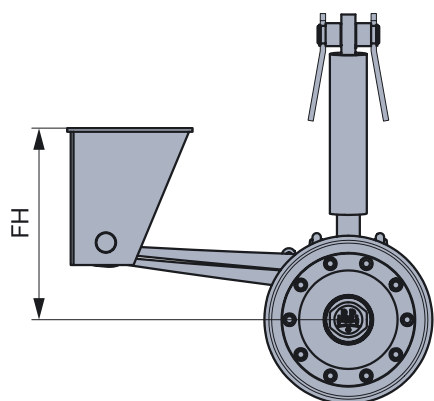
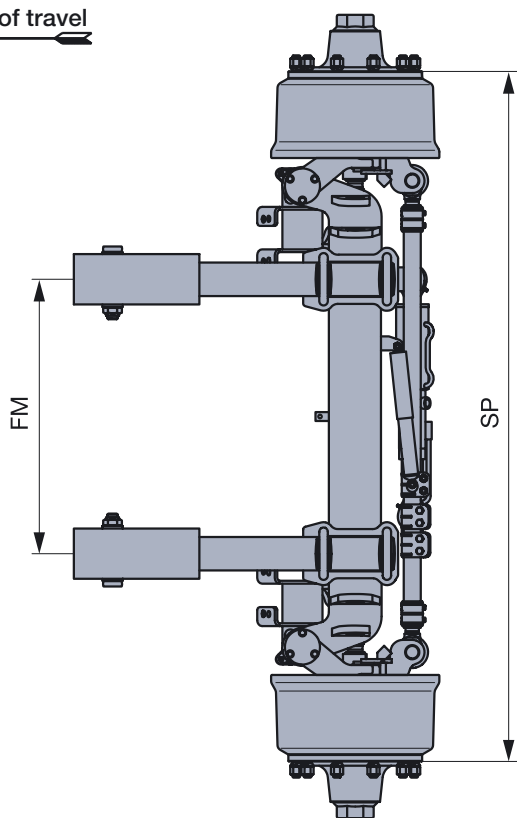

Especially spreaders, loaders and bowsers benefit from the smooth ride produced by large spring deflections and comprehensive dynamic axle load equalization. Thanks to the hydropneumatic concept, vehicle ride height remains consistent under all loading conditions. Of particular advantage with full load and high centre of gravity is the roll stabilization afforded by these suspensions plus there is plenty of room to fit an axle lift if required.

Name	BPW order no.	Suspension load kg	Speed (km/h)	Track Sp mm	Spring centre FM mm	Wheel brake type	Ride height FH mm	
GSOH	11010-1	56.88.08.0003	9000	60	1950	700	FL 4112	615
GSOHLA	11010-1	56.88.08.0004	9000	60	1950	800	FL 4112	615
GSOH	12010	56.72.08.0004	11000	60	1950	780	FL 4118	550
GSOHLL	12010	56.72.08.0003	11000	60	1950	780	FL 4118	550

Other dimensions available on request.

Delivered fully assembled.

Special type: Bolt-on frame attachment, prepared for tyre pressure control system, 65 km/h type in conjunction with automatic slack adjuster, ABS, complete with frame and brake system.

Sample applications: Sprayers, bowsers, pick-up trailers, spreaders