

Totalleverandør av materiell for vare-/båthenger og campingvogn



Hofstads %



INNHALDFORTEGNELSE

Gummitorjonsakseler, påløpsbrems, tilhengerchassi, støtdemper	5
Bremsekosett BPW, Peiz, Knott, AL-KO, Avonride	6
Påløpsdemper BPW, Peitz, Knott, AL-KO, sikkerhetswire	7
Bremsewire	8
Komplette hjul, stoppekloss	9
Kjøreramper	10
Stativ for kjøreramper, presenningsbøyer	11
Elastisk snor, trinse for snor, ATV-presenning	12
Plastskjermer, verktøykasse	13
Plastskjermer, stålskjermer	14
Overkjøringsrampe, gangbro	15
Båthengerutstyr	16
Trinse for vinsj, kulefester	17
Kulekobling, lås for kulekobling	19
Støttehjul/ben og tilbehør	20
Sidestøtte med tilbehør	21
Trapper for campingvogn	22
Elektrisk utstyr	23
Støpsel/kontakt/adapter	28
Finêrplater, hengsel, lemlås, surrefeste	29
Lastsikring, rullebuffer	31
Light Box verktøykasser, skap for brannslukker	32

BPW gummitorsjonsaksler, påløpsbrems og tilhengerchassi.



Kontakt oss for mer informasjon.

Aksler uten brems, maks 750 kg:



Aksler med brems, fra 850 kg til 1800 kg:



Påløpsbrems, maks 3500 kg:

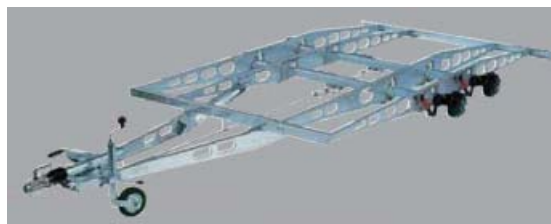

Tilhengerchassi, 2000 kg – 2700 kg – 3500 kg, finnes som autotransporter og universal (se under). En-akslet chassi med totalvekt 1500 kg kan også leveres, ta kontakt.

Autotransporter:

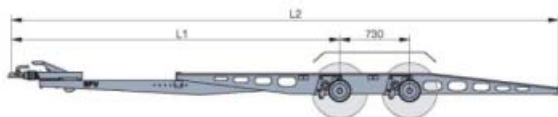

Universal:

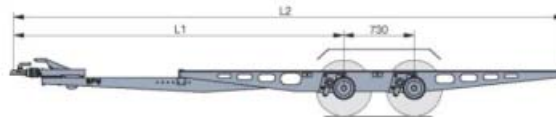

Støtdemper

Best.nr.
02.3722.39.00

Beskrivelse
Lengde 337/237 mm,
Ø12 øye.



Originale BPW reservedeler

Bremsekosett – komplett til 1 aksel inkl retur fjærer.

Best.nr.	Bremsekode – Beskrivelse – Type
09.801.03.63.0	S 2304-7 RASK – 230x40 mm – 2
09.801.03.64.0	S 2035-7 RASK – 200x35 mm – 2
09.801.03.65.0	S 2003-5 RASK – 200x30 mm – 3
09.801.03.66.0	S 1635-6 RASK – 160x35 mm – 3
09.801.03.68.0	S 2504-5 RASK – 250x40 mm – 3
09.801.03.75.0	S 3006-5 RASK – 300x60 mm – 3
09.801.03.79.0	S 2005-7 RASK – 200x50 mm – 2
09.801.03.80.0	S 2504-7 RASK – 250x40 mm – 2
09.801.03.81.0	S 3006-7 RASK – 300x60 mm – 2
09.801.03.82.0	S 1704-7 RASK – 170x40 mm – 1
09.801.06.85.0	S 2005-5 RASK – 200x50 mm – 3

Peitz:

Best.nr.	Bremsekode – Beskrivelse – Type
09.801.03.76.0	R 234-76 – 230x40mm – 4

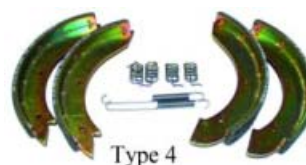
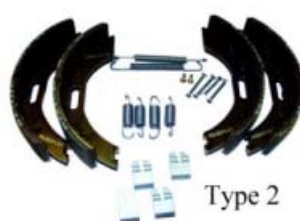
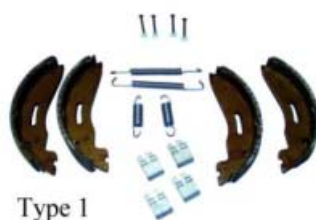

Bremsekosett AL-KO:

Best.nr.	Bremsekode	Dimensjon
SBA818-4	1635/1637	160 x 35 mm
SBA819-4	2035	200 x 35 mm
SBA817-4	2050/2051	200 x 50 mm
SBA816/4	2350	230 x 50 mm
SBA815-4	2360/2361	230 x 60 mm

Bremsekosett AVONRIDE:

Best.nr.	Bremsekode	Dimensjon
SBA847-4	20,32-1647	203 x 40 mm

Originale BPW reservedeler.



Gassdemper til påløpsbrems.

Best.nr.	Beskrivelse	Type
02.3722.47.00	PAV SR 1,3, A-S	1
02.3722.46.00	PAV SR 2,0, A-S	1
02.3702.48.00	PAV SR 2,7, A-S	1
02.3722.59.00	ZAF 1,0-1/-2	2
02.3722.27.01	ZAF 1,35-1/PAV SR 1,3X	1
02.3722.29.01	PAV SR 1,3 MX1	1
02.3722.52.01	ZAF 1,6-1	1
02.3722.25.01	ZAF 2,0-1/PAV SR 2,0 X	1
02.3722.43.00	ZAF 2,8-1/PAV SR 2,7 X	1
02.3702.65.00	ZAF 3,5-1	2
02.3722.75.00	ZAF 1,5-2	2
02.3722.77.00	ZAF 2,0-2	2
02.3722.80.00	ZAF 2,8-2	2
02.3722.07.00	KF 13/GTA 1,3	4
02.3722.08.00	KF 17/20/GTA 1,7/2,1	4
02.3702.55.00	GTA 1,6	3
02.3702.56.00	GTA 1,0	3



Sikringwire for påløpsbrems.

Best.nr.	05.327.00.26.0
----------	----------------



Gassdemper til påløpsbrems – AL-KO.

Best.nr.	Type påløpsbrems	L=
AD81161B-A	161 S (Ny)	505 mm
AD81251B-A	251 S (Ny)	505 mm
AD81120B-A	120 SR	
AD81161VB	161 VB	325 mm
AD81251C-A	251 S	325 mm
AD81251VB	251 VB	330 mm



Originale BPW (PEITZ) bremsewirer

Best.nr. bilde 1	Brems/Årstall	L mm	L1 mm	D1 mm	D2 mm	
05.089.33.36.0	BPW etter 1988	730	940	M 8	18,5	
05.089.33.37.0		830	1040	M 8	18,5	
05.089.33.41.0		S1635-6	1030	1240	M 8	18,5
05.089.33.43.0		S2003-5	1130	1340	M 8	18,5
05.089.33.44.0		S2005-5	1230	1440	M 8	18,5
05.089.33.47.0		S2504-5	1530	1740	M 8	18,5
05.089.33.48.0			1630	1840	M 8	18,5
05.089.51.41.0		BPW etter 1988	800	1060	M 10	25,5
05.089.52.76.0	S3006-5/6	1100	1360	M 10	25,5	
05.089.33.77.0	BPW etter 1995	730	955	M 8	23	
05.089.33.78.0			830	1055	M 8	23
05.089.33.80.0		S1704-7	930	1155	M 8	23
05.089.33.81.0		S2035-7	1030	1255	M 8	23
05.089.33.83.0		S2005-7	1130	1355	M 8	23
05.089.33.84.0		S2304-7	1230	1455	M 8	23
05.089.33.85.0		S2504-7	1330	1555	M 8	23
05.089.33.86.0			1430	1675	M 8	23
05.089.33.87.0			1530	1755	M 8	23
05.089.33.88.0			1630	1875	M 8	23
05.089.02.48.0			1990	2243	M 8	23

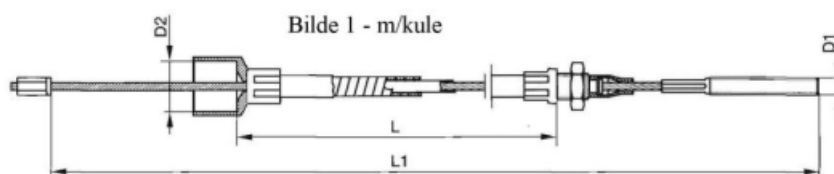

Best.nr. bilde 2	Brems/Årstall	L mm	L1 mm	D1 mm	D2 mm
05.089.03.22.0	Peitz /BPW før 1988	800	1095	M 8	14
05.089.03.23.0		900	1195	M 8	14
05.089.03.24.0	R160/76, R163/83, R234/76, S234 R, S2304-2, S1635-5, S1635-6, 2003-5, S2005-5, S2504-5	1000	1295	M 8	14
05.089.03.26.0		1175	1470	M 8	14
05.089.03.28.0		1300	1595	M 8	14
05.089.03.27.0		1525	1820	M 8	14
05.089.03.29.0		1725	2020	M 8	14

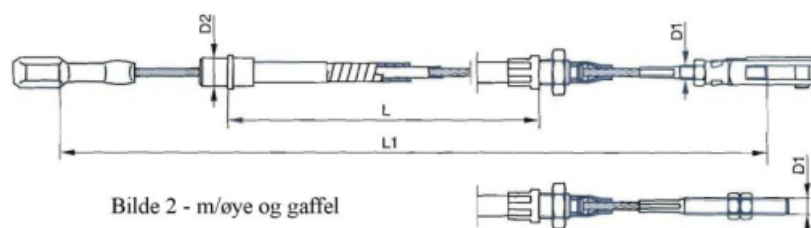

Komplette tilhengerhjul.

Best.nr./ Dimensjon	Belastning kg	Felgdata
5.00-10K4	355	60/100/4 ET 0
145R10K4	345	60/100/4 ET 0
145/70R13K4	380	57/100/4 ET 30
155R13C8K4M+S	630	57/100/4 ET 30
155R13C8K5M+S	630	63/112/5 ET 30
175/70R13K4	525	57/100/4 ET 30
175/70R13K4M+S	525	57/100/4 ET 30
175/70R13K5	525	63/112/5 ET 30
175/70R13K5M+S	525	63/112/5 ET 30
175R13C8K5	730	63/112/5 ET 30
195/50R13C8K5	900	63/112/5 ET 30
175/70R14K4	550	57/100/4 ET 30
185R14C8K4M+S	895	57/100/4 ET 30
185R14C8K5	895	67/112/5 ET 30
185R14C8K5M+S	895	67/112/5 ET 30
195/70R14K4	675	57/100/4 ET 30
195/70R14K4M+S	675	57/100/4 ET 30
195/70R14K5	675	67/112/5 ET 30
205R14C8K6	1080	161/205/6 ET 0



Trailerline stoppekloss.

Best.nr.	Beskrivelse
42.62202	Stoppekloss, 200 x 120 mm, vekt 1,75 kg.

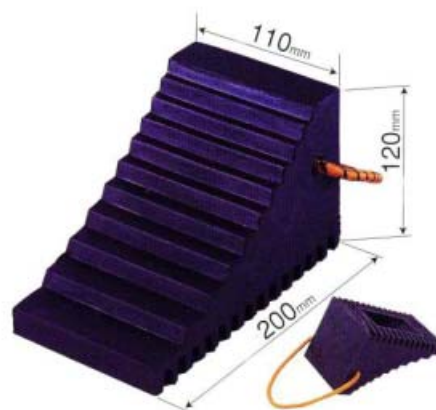

Trailerline Safety Ramps/kjøreramper.

Rette kjøreramper i aluminium. Leveres i sett a 2 stk.

Best.nr.	Betegnelsen	Belastning pr sett
55.1500L-200	1500 x 200 mm	400 kg
55.2000L-200	2000 x 200 mm	400 kg
55.2000L-260	2000 x 260 mm	1000 kg
55.2000L-260-2T	2000 x 260 mm	2000 kg
55.2000L-260-4T	2000 x 260 mm	4000 kg
55.2500L-260	2500 x 260 mm	1000 kg
55.2500L-260-2T	2500 x 260 mm	2000 kg
55.3000L-260	3000 x 260 mm	1000 kg
55.3000L-260-4T	3000 x 260 mm	4000 kg

Buede kjøreramper i aluminium. Leveres i sett a 2 stk.

Best.nr.	Betegnelsen	Belastning pr sett
55.1500B-200	1500 x 200 mm	400 kg
55.2000B-200	2000 x 200 mm	400 kg
55.2000B-260	2000 x 260 mm	1000 kg

Materialtykkelse:

200 mm bredde – 3 mm

260 mm bredde – 4 mm

Alle ramper har forsterket anleggsflate +3 mm.

Be om spesialbrosjyre.

Monteringsbeslag:

Best.nr. 55.SRF-01

Passer til 200 mm og 260 mm bredde.

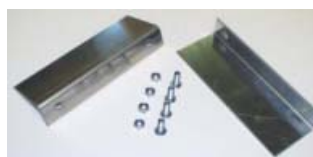
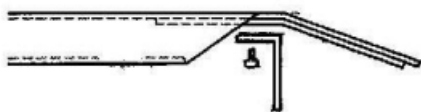

Stativ for kjøreramper

Best.nr. – 55.RS1

Leveres i grålakkert aluminium, med plass til 12-18 kjøreramper (avhengig av type).

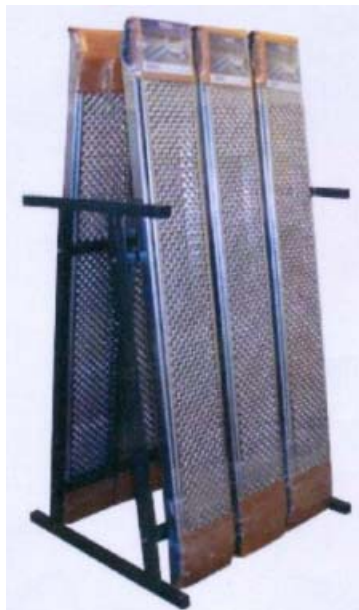

Trailerline presenningsbøyler.

Best.nr.	Beskrivelse
55.152040	Lengde 140 – 210 cm
55.101460	Lengde 100 – 145 cm
55.100300	Forlengelsesrør

55.152040
Aluminium, vekt kun 0,8 kg. Justerbar fra 140 til 210 cm. Anbefalt 2 – 3 stk pr tilhenger (langsmontert).

55.101460
Aluminium, vekt kun 0,6 kg. Justerbar fra 100 til 145 cm. Anbefalt 3 – 4 stk pr tilhenger (tverrmontert).



Trailerline elastisk snor.

Best.nr.	Beskrivelse
44.tcer730	Elastisk snor for tilhengerpresenninger, lengde 7,3 meter, inklusiv elastikksamlere.
44.tcer10000	Elastisk snor for tilhengerpresenninger, lengde 100 meter.



Trailerline trinse.

Best.nr.	Beskrivelse
44.pb20	Trinse, 20 stk.



Trailerline klemmringer for elastisk snor.

Best.nr.	Beskrivelse
44.sb50	Klemmringer for elastisk snor, 50 stk



ATV-presenning

Best.nr.	Beskrivelse
44.62142	Lengde 208 cm.
44.62143	Lengde 208-221 cm.



Trailerline plastskjermer.

Best.nr.	Farge/Hjul
48.mp10-01	Blå, for 10" hjul
48.mp13-02	Sort, for 13" hjul

48.mp10-01: Lengde 650 mm, bredde 170 mm, høyde 285 mm.

48.mp13-02: Lengde 690 mm, bredde 200 mm, høyde 325 mm.



Trailerline verktøykasser.

Best.nr.	Beskrivelse
48.tbp-02	Verktøykasse til tilhenger og båthenger, lengde 655 mm, bredde 350 mm, høyde 330 mm, sort.

Produsert i kraftig kunststoff. Vekt kun 3,5 kg.



Monteringsbeslag for verktøykasse.

Best.nr.	Beskrivelse
48.tbpsu-02	Sort

Monteringsbeslaget leveres komplett med 2 stk braketter, bolter, muttere, kroker og gummistropp.



Plastskjermer

Best.nr.	Beskrivelse
H 5308	Sort plastskjerm for 10" hjul
H 5313	Sort plastskjerm for 13" hjul

Bredde	B	C
170	285	650
200	325	690

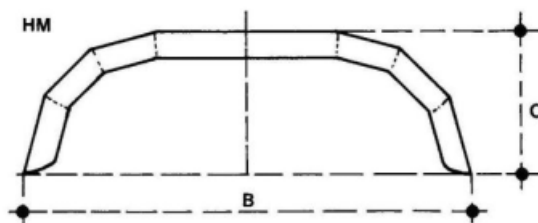

Stålskjermer, galvanisert

Best.nr.	Beskrivelse
S35HR1968SMV	For 12" hjul
S35HR2075SMV	For 13" hjul
S35THRV22155SMV	Boggiskjerm, for 13" hjul

Bredde	B	C	D
190	680	330	325
200	750	380	360
220	1550	375	375

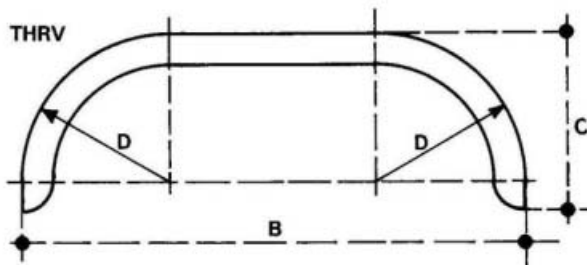
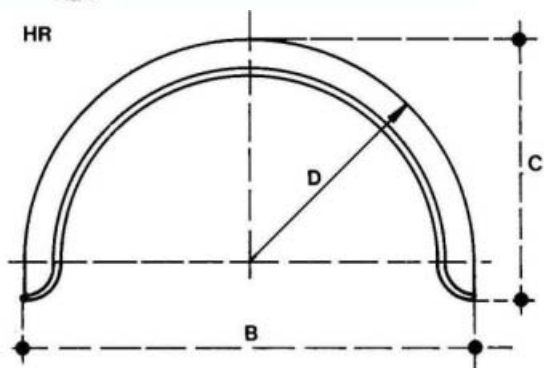

Trailerline overkjøringsrampe.

Best.nr.	Beskrivelse
55.dt3-700	Rampe for sekke-tralle etc. Består av 3 deler inkl skruer, høyde 40 mm. Brukes ved overkjøring av dørterskler, rør, etc.



Trailerline gangbro for båthenger.

Produsert i aluminium, tåler en belastning på 200 kg.

Best.nr.	Beskrivelse
55.400L-200-S	Lengde 400 mm
55.600L-200-S	Lengde 600 mm
55.800L-200-S	Lengde 800 mm
55.1000L-200-S	Lengde 1000 mm
55.1200L-200-S	Lengde 1200 mm

Beslag for gangbro

Best.nr.	Beskrivelse
42.SRSU/01	Komplett beslag m/U- bøyle. Minimum 2 stk pr gangbro.

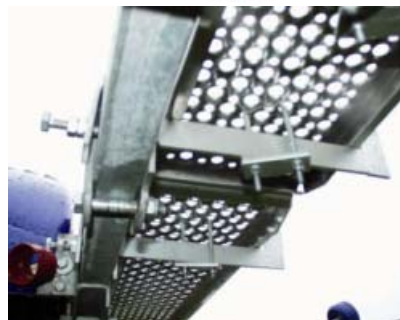

Trailerline båthengerutstyr.

Best.nr. 26475 Beskrivelse
Baugstøtte, Ø22 mm hull.

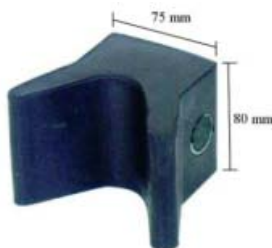

Best.nr. 26435 Beskrivelse
Siderull, største diameter 120 mm, Ø22 mm hull.

26438 Siderull, største diameter 145 mm, Ø22 mm hull



Best.nr. 26405 Beskrivelse
Kjølrull, bredde 190 mm, største diameter 83 mm, Ø22 mm hull.



Best.nr. 800L7 Beskrivelse
Håndvinsj, 800 kg, 8 meter bånd, galvanisert to-veis vinsj med krok.



Best.nr. Q002925 Beskrivelse
Håndvinsj, 1130 kg, 7,5 meter bånd



Trinser

Best.nr.	Beskrivelse
49.kses-01	For modell ES1100-ES1550. Max belastning 6000 kg.
49.kses-02	For modell ES2700-ES4500. Max belastning 12000 kg
49.kses-03	For modell ES6800. Max belastning 15000 kg.



49.kses-01



49.kses-02/03

Kulefeste/tilhengerfeste

Best.nr.	Beskrivelse
1610	50 mm kule, 2000 kg.
P-2805019	50 mm kule, 2 x Ø17 mm festehull med CC 90 mm, 3500 kg.

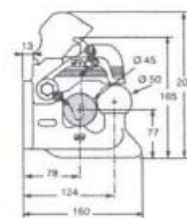

P-2905723	50 mm kule, 3500 kg.
-----------	----------------------

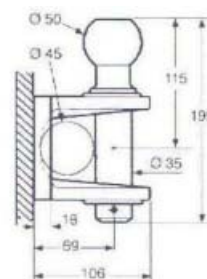
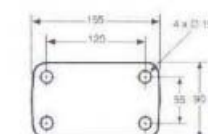

P-2944734	50 mm kule, 2000 kg.
-----------	----------------------

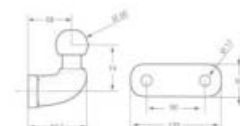

P-2944735	50 mm kule, 2500 kg.
-----------	----------------------

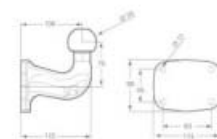

Kulekobling.

Kulekobling for tilhenger uten brems.

Best.nr.	Beskrivelse
WW 8-A	For Ø50 mm rør
WW 8-B	For Ø60 mm rør
WW 8-C	For Ø70 mm rør
WW 8-E	For 50x50 mm firkant
WW 8-G	For 60x60 mm firkant
WW 8-H	For 70x70 mm firkant



Kulekobling for tilhenger med brems.

Best.nr.	Beskrivelse
1146	Kulekobling WW 30-KZ, 50 mm kule, passer for trykkstang Ø35/40/45/46/50/51 mm. 3000 kg.



1450	Kulekobling WS 3000, stabilisatorkobling, 50 mm kule, passer for trykkstang Ø35/40/45/46/50/51 mm. 3000 kg.
------	---



WW 200-C7	For rør Ø70 mm, 50 mm kule, 3000 kg.
-----------	--------------------------------------

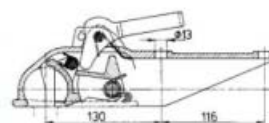

WW 300-H	For rør Ø50 mm, 60 mm kule, 3000 kg.
----------	--------------------------------------

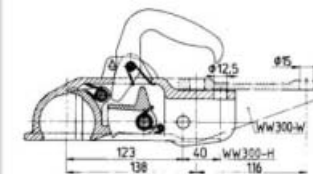

WW 300-W	For rør Ø70 mm, 60 mm kule, 3000 kg.
----------	--------------------------------------

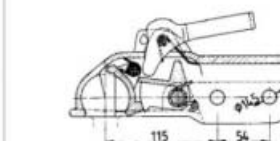

WW 350-B7	For rør Ø50 mm, 50 mm kule, 3500 kg.
-----------	--------------------------------------

Kulekobling.

WW 13-N For rør Ø46 mm,
50 mm kule, 1500 kg.

WW 150-RB For rør Ø50/51 mm,
50 mm kule, 1500 kg.

1135 For rør Ø46 mm,
50 mm kule, 3000 kg.

WW 200 B3 For rør Ø46 mm,
50 mm kule, 3000 kg.

WW 200 B5 For rør Ø50/51 mm,
50 mm kule, 3000 kg.

WW 350-B5 For rør Ø50 mm,
50 mm kule, 3500 kg.

1140 For rør Ø50/51 mm,
50 mm kule, 3000 kg.

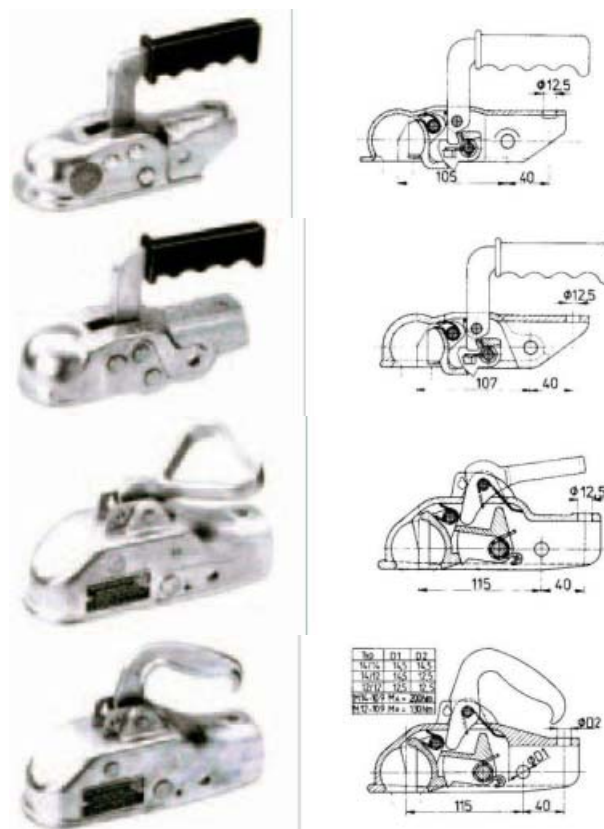

Trailerline lås.

Safety-Lock tilhengerlås.

Best.nr.: 55sl-2

Safety-Lock 55sl-2 kan brukes både når tilhengeren er parkert, og når tilhengeren er koblet på bilen. Passer på de fleste kulekoblinger. Leveres med hengelås.



Safety-Box med diskoslås.

Best.nr.: 4903300



Pikkolo koblingshjelp

Best.nr.: 48.us-36



Støtthjul/ben

6030/
55.STMP-02



6050



4068



02.3712.21.00



3014



T-6085



21.101-04



48.STB1000



Best.nr.	Beskrivelse
6030	Ø48 u/klemme, kunststoff-felg med kompakt hjul, Ø200x50 mm. Max belastning 150 kg.
55.STMP-02	Ø48 u/klemme, stålfelg med kompakt hjul Ø200x50 mm. Max belastning 100 kg.
6050	Ø48 u/klemme, kunststoff-felg med luftfylt hjul Ø260x85 mm. Max belastning 150 kg.
4068	Ø60 u/klemme, stålfelg med kompakt hjul Ø250x85 mm. Max belastning 250 kg.
02.3712.21.00	Automatisk vipping, 60 mm firkantør, stålfelg med kompakt hjul Ø200x50 mm. Max belastning 250 kg.
3014	Ø48 mm, rørlengde 600 mm, fotstørelse Ø90 mm.
T-6085	Støtthjul med innebygget vektskala 0-125 kg. Kompakt hjul Ø240x48 mm.
21.101-04	Automatisk vipping, Ø60 mm, Ø200x50 mm kompakt hjul. 250 kg.
48.STB1000	Støttestensett inkl 2 stk støtteben 1000 mm med klemmer.

Klemme

Best.nr.	Beskrivelse
1819	For Ø48 rørdiameter.
1844	Ø48 rørdiameter – forsterket.
3640	For Ø60 rørdiameter.

1819



1844



3640



Hjul

Best.nr.	Beskrivelse
200 VB	Kompakt, blikkplatefelg, 200 x 50 mm, maks 200 kg.
200 V	Kompakt, kunststoff-felg, 200 x 50 mm, maks 200 kg.
260 LB	Luftfylt, blikkplatefelg, 260 x 85 mm, maks 200 kg.
260 L	Luftfylt, kunststoff-felg, 260 x 85 mm, maks 200 kg.

200 VB



200 V



260 LB



260 L



Sidestøtter.

Best.nr.
02.3708.42.00

Beskrivelse
Utsveivbar 430 mm, vekt
4,2 kg, max belastning 500
kg.

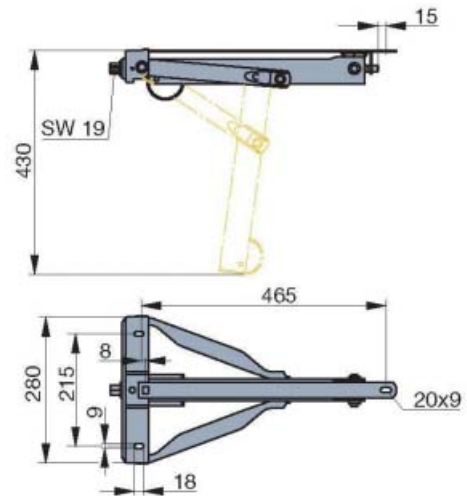

05.803.02.37.0

Utsveivbar 480 mm, vekt
5,6 kg, max belastning 750
kg.

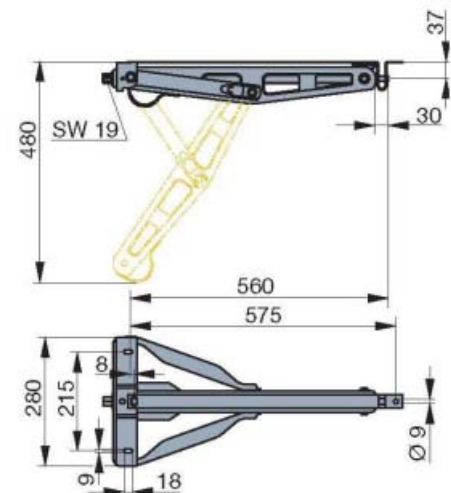

Sveiv for sidestøtte.

Best.nr.
02.1404.06.00

X = 650 mm

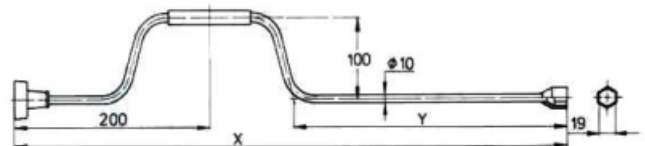

Lang pipe for sidestøtte.

Best.nr.
48.ht-01

Beskrivelse
Lang pipe for sidestøtte.
Ved bruk av drill. NV 19.



Trailerline trapper.

Best.nr. 48.ssr100 Beskrivelse
Ett-trinns trapp, grå stålramme med sklisikker gummimatte.

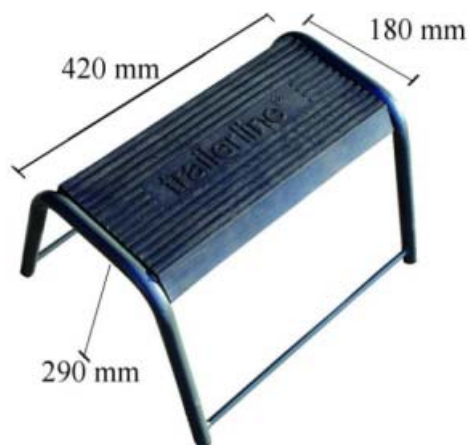

48.sdr200 To-trinns trapp, grå stålramme med sklisikker gummimatte.

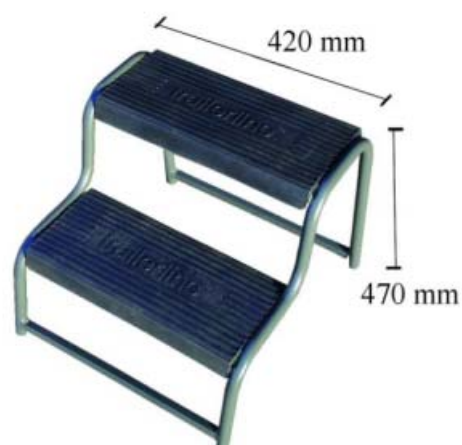

48.sdw300 Stasjonær to-trinns trapp, grå stålramme med trelameller. Høyde 470 mm.

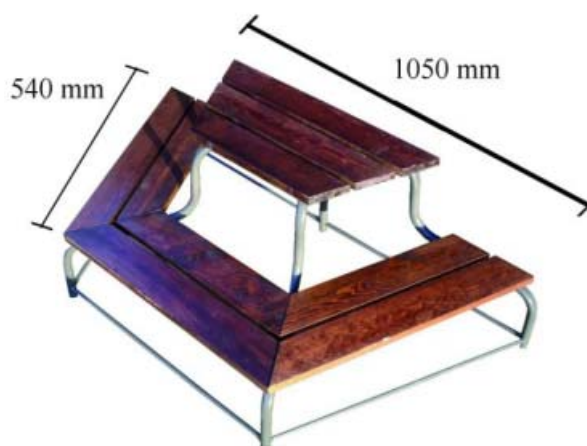

Plastfot for trapper.

Best.nr. 48.pfs-01 Beskrivelse
Plastfot for trapper, sett av 4 stk. Hindrer nedsynking i underlag.



Elektrisk utstyr.

Aspöck baklampe Multipoint II.

- | | |
|-------------|---|
| Best.nr. | Beskrivelse |
| 24-7000-007 | Venstre baklampe 12V med skiltlys, bajonettkobling for kabel. |
| 24-7200-007 | Høyre baklampe 12V, bajonettkobling for kabel. |
| 24-7210-007 | Høyre baklampe 12V med skiltlys og ryggelys, bajonettkobling for kabel. |

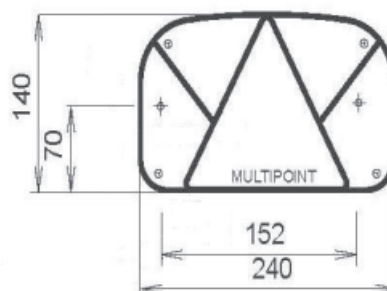

Aspöck baklampe Multipoint I.

- | | |
|-------------|---|
| Best.nr. | Beskrivelse |
| 24-5000-007 | Venstre baklampe 12V med skiltlys, bajonettkobling for kabel. |
| 24-5200-007 | Høyre baklampe 12V, bajonettkobling for kabel. |

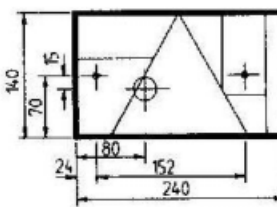
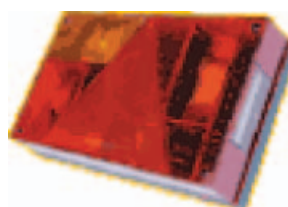

Aspöck baklampe Minipoint

- | | |
|-------------|---|
| Best.nr. | Beskrivelse |
| 23-0200-507 | Baklampe u/skiltlys, bajonettkobling for kabel. |

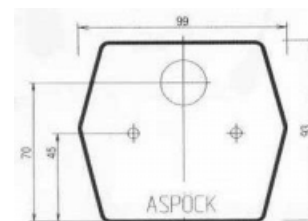

Aspöck baklampe Earpoint III

- | | |
|-------------|--|
| Best.nr. | Beskrivelse |
| 24-4700-007 | Venstre baklampe 12V, bajonettkobling for kabel. |
| 24-4800-007 | Høyre baklampe 12V, Bajonettkobling for kabel. |



- | | |
|-------------|---------------------------|
| 15-5303-007 | Brakett for Earpoint III. |
|-------------|---------------------------|



Jokon lampeserie 735 LED

LED-lampene i 735 serien er klare for tilkobling, vanntette og utstyrt med en tilslutningskabel på 500 mm. 12V.

Best.nr.	Beskrivelse
10.0018.000	Blink, brems, baklys
13.3024.000	Tåkelys, rød reflektor
13.6022.000	Ryggelys, rød reflektor
10.0020.000	Brems, baklys
13.1027.000	Blinklys
13.6020.000	Ryggelys
13.3022.000	Tåkelys
13.3102.000	Tåke, ryggelys

10.0018.000



13.3024.000



13.6022.000



10.0020.000



13.1027.000



13.6020.000



13.3022.000



13.3102.000

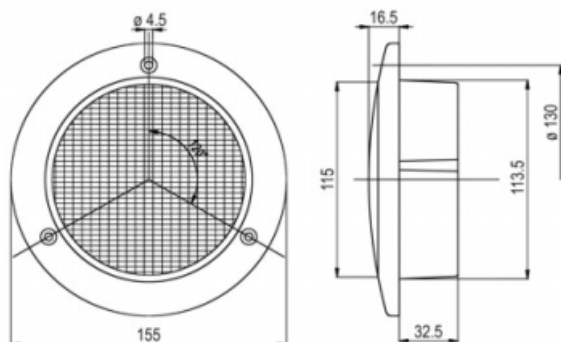

Aspöck markeringslys FlatpointII

Best.nr.	Beskrivelse
31-2369-047	Diode sidemarkering gul m/brakett 90°, 12 V.

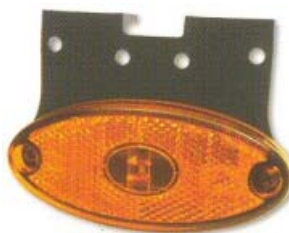

Jokon markeringslys

Best.nr.	Beskrivelse
11.1001.251	Mark.lampe hvit m/gummifeste.



191016.000	Reserveglass.
------------	---------------

Jokon LED markeringslys

LED lys for påbygging, 4 lysdioder.

Best.nr.	Beskrivelse
13.0012.000	Rød
13.5021.000	Hvit

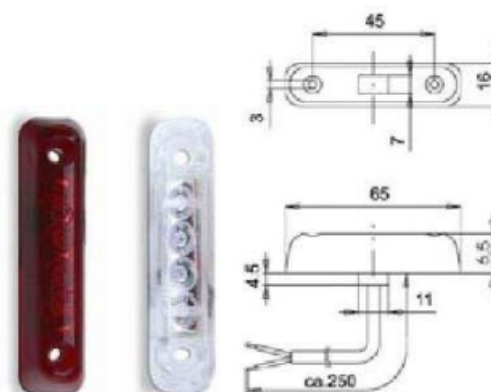

Ermax LED lys på gummiarm.

Best.nr.	Beskrivelse
098 241 016	Kort, 1 lysdiode
098 241 026	Vinklet, 1 lysdiode
098 241 086	Skrå, 1 lysdiode

098 241 016



098 241 026



098 241 086

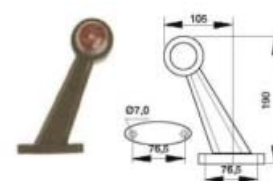

Ermax varsel-lamper

Best.nr.	Beskrivelse
098 286 326	LED varsellys, gul, programmerbar 12/24 V

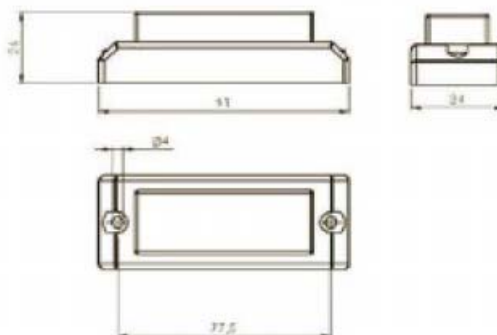

Best.nr.	Beskrivelse
098 985 710	LED varsellys, gul, blink, 10-30 V

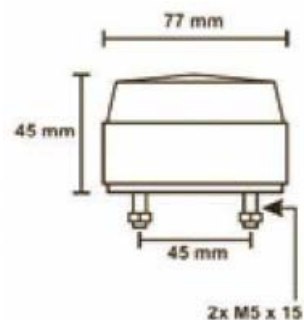

Ermax LED markeringslys

Best.nr.	Beskrivelse
098 203 601	Rød, 4 dioder, 9-33 V, 0,5 m kabel
098 230 601	Hvit, 4 dioder, 9-33 V, 0,5 m kabel
098 221 601	Gul, 4 dioder, 9-33 V, 0,5 m kabel

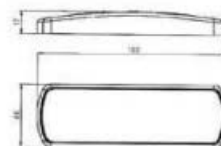

Ermax LED markeringslys

Markeringslys med kabel 12/24v E-godkjent. 3 led.

Best.nr.	Beskrivelse
098 221 876	Gul m/0,5 meter kabel
098 201 875	Rød m/5 meter kabel
098 231 875	Hvit m/5 meter kabel

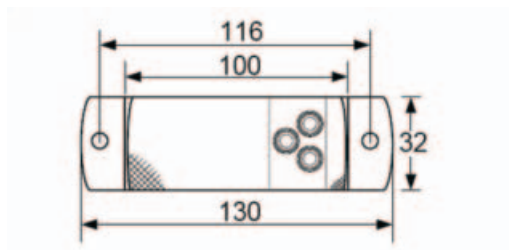

Ermax arbeidslys med LED teknologi.

Lampene har et solid hus i metall med frontramme i kunststoff. 50 cm tilkoblingskabel. Innebygd vern mot overspenning og omvendt polaritet.

Arbeidstemperatur: -40 til +50 C. Lysfordeling: 40 grader horisontalt og 25 grader vertikalt. 10 – 60 V.

Best.nr.	Beskrivelse
098 174 100	Arbeidslys med 3 stk 3' generasjon led teknologi. Lysstyrke 500 lumen. Stømförbruk 1,2A ved 12V og 0,6A ved 24V.
098 174 102	Arbeidslys med 6 stk 3' generasjon led teknologi. Lysstyrke 1000 lumen. Strömforbruk 1,8A ved 12V og 0,6A ved 24V.
098 174 104	Arbeidslys med 8 stk 3' generasjon led teknologi. Lysstyrke 1400 lumen. Strömforbruk 3A ved 12V og 1,8A ved 24V.

3 stk LED



6 stk LED



8 stk LED



Støpsel/Kontakt/Adapter

Best.nr.	Beskrivelse
005549	Adapter, 7-pol til 13-pol.
005600	Adapter, 13-pol til 7-pol.



EH-01	Kontakt, 7-pol, metall.
D7222	Kontakt, 7-pol, kunststoff.



EH-03	Støpsel, 7-pol, metall.
ST7120	Støpsel, 7-pol, kunststoff.



Aspöck strøm kabel med støpsel.

Best.nr.	Beskrivelse
58-1022-037	4 m
58-1022-057	7 m
58-1098-677	7 m + 4 m
58-1022-327	9 m



Diverse kabel.

Best.nr.	Beskrivelse
099 891 101	1 x 1,5, rull â 100 m
099 897 320	2 x 1,5, rull â 50 m
099 897 235	3 x 1,5, rull â 50 m
099 897 056	5 x 1,5, rull â 50 m
099 897 078	7 x 1,5, rull â 50 m
099 897 102	10 x 1,5, rull â 50 m
099 897 122	12 x 1,5, rull â 50 m
099 897 295	12 x 1,5/3 x 2,5, rull â 25 m

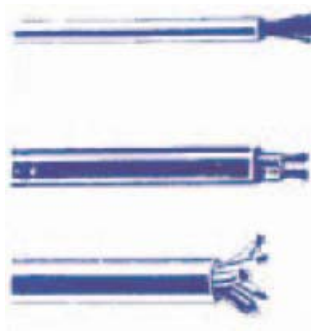

Spiralkabel

Best.nr.	Beskrivelse
6-30075.30	Spiralkabel med ISO1724 støpsel, 7 leder, 3 m.



Finnforrest – Finérplater.

Best.nr./mål	Vekt
9 x 1500 x 2500 mm	26,0 kg
12 x 1500 x 2100 mm	27,7 kg
12 x 1500 x 2500 mm	33,0 kg
15 x 1500 x 2500 mm	41,0 kg

MetsaDeck finérplater med not og fjær på langsiden. Den ene siden er ru, den andre siden er glatt.

15 x 1500 x 3000 mm Uten not og fjær



Trailerline galvanisert hengsel

Best.nr.	Beskrivelse
6510472	Hengseltapp 112 x 77 mm.
6510481	Hengselleie 77 x 25 mm.



Trailerline lemlås og motjern.

Best.nr.	Beskrivelse
42.hl-01	Galvanisert lemlås, 223 x 88 mm, med øye for hengselås.
42.khl-01	Galvanisert motjern, 144 x 35 mm.

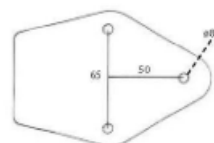

Trailerline vinkellukker

Best.nr.	Beskrivelse
3990-00-2100	Vinkellukker, utformet som et 7-tall, 175x105 mm.
3990-00-2200	Vinkellukker, utformet som et omvendt 7-tall, 175x105 mm.
3520-00-6000	Øye for vinkellukker, 90x50 mm.



Furgocar hengsel.

Best.nr. Beskrivelse
 F-102006170 Sidedørshengsel for enkle
 bruksområder. Maskinpolert.

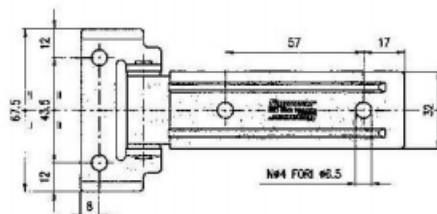
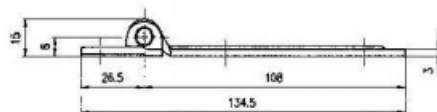

F-101506350 Sidedørshengsel i rustfritt stål.
 Maskinpolert.

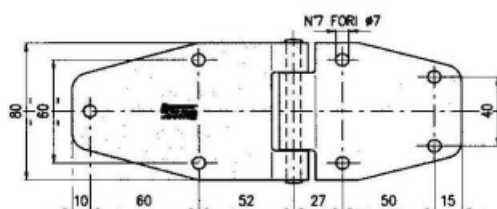
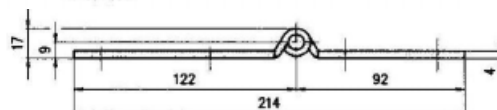

Surrefester

Best.nr. Beskrivelse
 26300 Surrekrok for sveising.
 26301 Surrekrok for skruing,
 galvanisert.



26310 Galvanisert binding, 600 kg
 bruddstyrke.



170-21 G Galvanisert dyrebinding.



22885 Kjellerlemkrok, 1000 kg
 bruddstyrke

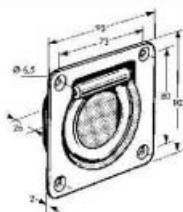

Lastsikringsstropper

Best.nr. 05036
 Beskrivelse
 Hjulsurring m/krok og ring.
 Bruddstyrke 2500 kg.



Best.nr. 01031A
 Beskrivelse
 Hobbystrammer m/skralle og
 krok, 0,4 + 4,6 m, bruddstyrke
 500 kg.

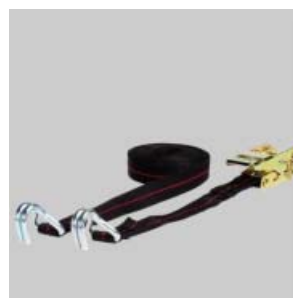

Best.nr.
 Beskrivelse
 Strammebånd m/skralle og
 krok, 0,5 + 4,5 m, 35 mm
 bånd, bruddstyrke 2000 kg.



Rullebuffer

Best.nr. 83160
 Beskrivelse
 L = 75, H = 90, D = 93, 0,9 kg.
 83170
 L = 140, H = 90, D = 93, 2,1 kg.
 83180
 L = 205, H = 90, D = 93, 3 kg.

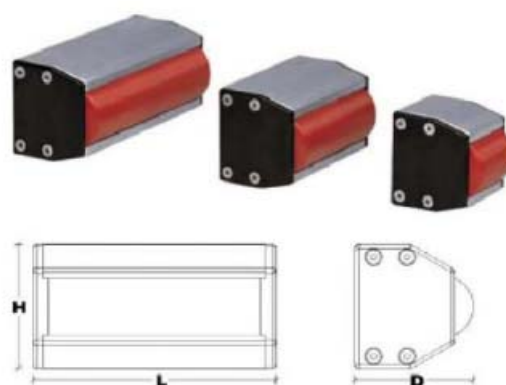

Light Box verktøykasser

Hofstads AS presenterer en ny verktøykasse for den profesjonelle bruker. I utviklingen er det satt fokus på vekt og kvalitet. Kassene har aluminiumshus med valg av lokk i polert rustfritt stål eller eloksert aluminium. Vektseksempel AR-5-0972 – ca 15 kg.

Best.nr.	Beskrivelse
AA-5-0593	593x500x500 mm, alu-lokk
AA-5-0800	800x500x500 mm, alu-lokk
AA-5-0972	972x500x500 mm, alu-lokk
AR-4-0593	593x400x400 mm, rustfritt lokk
AR-5-0593	593x500x500 mm, rustfritt lokk
AR-5-0800	800x500x500 mm, rustfritt lokk
AR-5-0972	972x500x500 mm, rustfritt lokk
AR-6-0593	593x600x600 mm, rustfritt lokk
AR-6-0800	800x600x600 mm, rustfritt lokk
AR-6-0972	972x600x600 mm, rustfritt lokk



AA



AR

Skap for brannslukker

L = 310 mm, H = 675 mm, D = 250 mm, vekt 2,87 kg

Best.nr.	Beskrivelse
82020	For slukker med diameter Ø160 mm
82030	For slukker med diameter Ø180 mm

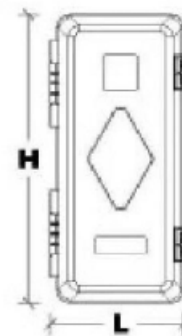
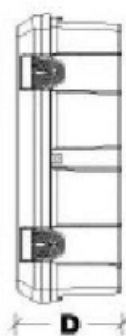

HOFSTADS A/S

ALMINNELIGE LEVERINGSBETINGELSER

Disse alminnelige leveringsbetingelser gjelder dersom ikke annet er skriftlig avtalt mellom partene.

1. **Produkt-informasjoner:** Alle oppgaver, illustrasjoner, tegninger vedrørende dimensjoner, tekniske spesifikasjoner, priser m.v. i kataloger, brosjyrer, prospekter, sirkulærer og lignende er bare veiledende.
2. **Priser:** Når ikke annet er angitt, gjelder prisene fob. Oslo, eks. emballasje og merverdiavgift. De oppgitte priser er bindende innenfor et angitt tidsrom. Nødvendige prisforhøyelser kan dog foretas p.g.a. endringer i valutakursen.
3. **Forsikring:** Kjøperen sørger for forsikring.
4. **Risiko:** Risikoen for varen går alltid over på kjøperen når forsendelsen påbegynnes fra selgerens lager.
5. **Leveringstid:** Den oppgitte leveringstid er veiledende. Den seneste av følgende tidspunkter gjelder som utgangspunkt for beregningen av leveringstiden:
 - a. Den dag bestillingen, eventuelt de endelige spesifikasjoner er mottatt.
 - b. Den dag selgeren mottar den betaling som eventuelt skal erlegges forskuddsvis, eller avtalt garanti er stillet.
 Selgeren er ikke erstatningsansvarlig ved forsinket levering.
6. **Betalings-betingelser:** Betaling skal skje 30 dager fra fakturadato. Etter forfall beregnes purregebyr og morarente.
7. **Eiendoms-forhold:** Selgeren beholder eiendomsretten til de leverte varer inntil kjøpesummen er betalt i sin helhet. Aksept anses ikke som betaling før den er innfridd.
8. **Undersøkelses-plikt og reklamasjoner:** Kjøperen skal undersøke varen straks etter mottagelsen. Reklamasjoner skal skje skriftlig, inneholde oppgave over mangelens art og omfang og må være avgitt senest 8 – åtte – dager etter varens mottagelse.
9. **Mangels beføyelser og garanti:** Selgeren forplikter seg til å avhjelpe alle mangler som skyldes feil i konstruksjon, materiale eller tilvirking i overensstemmelse med det som er fastsatt under pkt. a – d nedenfor.
 - a. Selgerens ansvar omfatter bare mangler som viser seg i løpet av 1 år fra den dag varen ble levert. For drivakslar er ansvaret dog begrenset til å gjelde i 6 måneder, dog maksimum for 800 brukstimer.
 - b. Selgeren har valget mellom å avhjelpe mangelen, foreta omlevering eller helt eller delvis godtgjøre varens fakturaverdi.
 - c. materiale eller tilvirking i overensstemmelse med det som er fastsatt under Dersom selgeren avhjelper mangelen eller foretar omlevering innen rimelig tid, har kjøperen ikke rett til å heve kjøpet. Krav om å heve kjøpet må fremsettes skriftlig straks det er konstatert at mangelen ikke vil bli avhjulpet eller omlevering ikke vil bli foretatt innen rimelig tid. Under ingen omstendighet har kjøperen rett til å heve kjøpet dersom mangelen ikke er vesentlig.
 - d. Utover det som er bestemt i a – c påtar selgeren seg intet ansvar for skade eller tap som følge av mangelfull levering. Selgeren har heller intet ansvar for skade eller tap som måtte oppstå for kjøperen som følge av varens videre anvendelse eller konsekvensskader av noen som helst art.
10. **Force majeure:** Følgende omstendigheter skal betraktes som fritagelsesgrunner, dersom de inntreffer etter avtalens inngåelse og hindrer dens oppfyllelse: arbeidskonflikt og enhver annen omstendighet, når partene ikke kan råde over den, så som brann, krig, mobilisering eller uforutsette militære innkallelser av tilsvarende omfang, rekvisisjon, beslag, valutarestriksjoner, opprør og oppløsning, knapphet på transportmidler, alminnelig vareknapphet, kassasjon av større arbeidsstykker, innskrenkninger i tilførselene av drivkraft, samt mangler ved leveranser fra underleverandører eller forsinkelser av slike leveranser som følge av slik omstendighet som omhandles i dette punkt.
11. **Kjøperens innkjøpsbetingelser:** Kjøperens innkjøpsbetingelser får ikke anvendelse.



Hofstads AS

OSLO

Ringnesveien 23
Postboks 25 Haugenstua
0915 Oslo
Telefon 22 10 10 50
Telefaks 22 21 55 75

TRONDHEIM

Kvenildmyra 7
Postboks 179 Tiller
7476 Tiller
Telefon 72 89 40 50
Telefaks 72 89 40 60

TROMSØ

Alkevegen 2
Postboks 2095
9266 Tromsø
Telefon 77 67 13 74
Telefaks 77 67 18 91

www.hofstads.no